



Designation: D7059 – 21

Standard Test Method for Determination of Methanol in Crude Oils by Multidimensional Gas Chromatography¹

This standard is issued under the fixed designation D7059; the number immediately following the designation indicates the year of original adoption or, in the case of revision, the year of last revision. A number in parentheses indicates the year of last reapproval. A superscript epsilon (ϵ) indicates an editorial change since the last revision or reapproval.

1. Scope*

1.1 This test method covers the determination of methanol in crude oils by direct injection multidimensional gas chromatography in the concentration range of 15 ppm (m/m) to 900 ppm (m/m). The pooled limit of quantification (PLOQ) is 15 ppm (m/m).

1.2 This test method is applicable only to crude oils containing less than or equal to 0.1 % (v/v) water.

1.3 This test method has not been tested with crude oil samples that are solid or waxy, or both, at ambient temperatures.

1.4 The values stated in SI units are to be regarded as standard. Alternate units, in common usage, are also provided to increase clarity and aid the users of this test method.

1.5 *This standard does not purport to address all of the safety concerns, if any, associated with its use. It is the responsibility of the user of this standard to establish appropriate safety, health, and environmental practices and determine the applicability of regulatory limitations prior to use.*

1.6 *This international standard was developed in accordance with internationally recognized principles on standardization established in the Decision on Principles for the Development of International Standards, Guides and Recommendations issued by the World Trade Organization Technical Barriers to Trade (TBT) Committee.*

2. Referenced Documents

2.1 *ASTM Standards:*²

- D4006 Test Method for Water in Crude Oil by Distillation
- D4057 Practice for Manual Sampling of Petroleum and Petroleum Products

¹ This test method is under the jurisdiction of ASTM Committee D02 on Petroleum Products, Liquid Fuels, and Lubricants and is the direct responsibility of Subcommittee D02.04.0L on Gas Chromatography Methods.

Current edition approved Dec. 1, 2021. Published December 2021. Originally approved in 2004. Last previous edition approved in 2017 as D7059 – 09 (2017). DOI: 10.1520/D7059-21.

² For referenced ASTM standards, visit the ASTM website, www.astm.org, or contact ASTM Customer Service at service@astm.org. For *Annual Book of ASTM Standards* volume information, refer to the standard's Document Summary page on the ASTM website.

- D4175 Terminology Relating to Petroleum Products, Liquid Fuels, and Lubricants
- D4307 Practice for Preparation of Liquid Blends for Use as Analytical Standards
- D4928 Test Method for Water in Crude Oils by Coulometric Karl Fischer Titration
- D6596 Practice for Ampulization and Storage of Gasoline and Related Hydrocarbon Materials
- E355 Practice for Gas Chromatography Terms and Relationships
- E594 Practice for Testing Flame Ionization Detectors Used in Gas or Supercritical Fluid Chromatography

3. Terminology

3.1 Definitions:

3.1.1 This test method makes reference to common gas chromatographic procedures, terms, and relationships. Detailed definitions of these can be found in Practices E355 and E594, and Terminology D4175. Additional definitions and information pertinent to this test method are listed below.

3.1.2 *analytical column, n*—porous layer open tubular (PLOT) column with a stationary phase selective for oxygenates; it is used to resolve methanol from 1-propanol to provide accurate quantitative results.

3.1.3 *cool-on-column injector, n*—an injection port that allows controlled injection of the sample at a temperature close to or lower than the boiling point of the solvent into the gas chromatographic column or a liner within the injection port connected to the column.

3.1.3.1 *Discussion*—After the injection, the injection port is heated at a fixed rate to a temperature sufficiently high enough to allow the transfer of sample components of interest from the injection port to the part of the column located in the gas chromatograph (GC) oven.

3.1.4 *electronic pressure control, n*—electronic pneumatic control of carrier gas flows; it can be flow or pressure programmed to speed up elution of components.

3.1.5 *low-volume connector, n*—a special union for connecting two lengths of tubing 1.6 mm inside diameter and smaller; sometimes referred to as a zero dead-volume union.

3.1.6 *pre-column, n*—a polydimethylsiloxane WCOT column used to isolate the methanol and 1-propanol and several

*A Summary of Changes section appears at the end of this standard

TABLE 1 Operating Conditions for Configuration A

Injector	On-column. Temperature program: 50 °C (0.1 min) 30 °C/min to 300 °C until end of oven program; 1.0 microlitre injected with autosampler
Oven	40 °C at 2 °C/min to 70 °C (0 min); 4 °C/min to 190 °C; 30 °C/min to 250 °C (13.0 min)
temperature program	
Detectors	Two flame ionization detectors (FID) at 325 °C. Hydrogen at 30 mL/min; air at 300 mL/min; helium make-up gas at 30 mL/min
Columns	60 m × 0.53 mm ID 5.0 µm film polydimethylsiloxane (pre-column) 10 m × 0.53 mm ID 10 µm film CP-Lowox The two columns are coupled through a four-port Valco valve as shown in Fig. 1 When analyses are not being performed, the GC oven temperature should be kept at 250 °C, and the pre-column carrier head pressure kept at 60 psi. This procedure conditions the CP-Lowox column, which may trap carrier gas contaminants at the normal 40 °C starting temperature, and also elutes residual heavy material from the pre-column.
Carrier gas	Pre-column: 10 psi (20 min) 99 psi/min to 60 psi (until end of oven temperature program)
Valve temperature	CP-Lowox column flow: constant flow of 10 mL/min 260 °C
Valve timing	1. Valve on at 2.80 min and off at 4.00 min to transfer the methanol from the polydimethylsiloxane column to the CP-Lowox column 2. Valve on at 6.80 min and off at 8.00 min to transfer the internal standard, 1-propanol

light hydrocarbons from the higher boiling portion of the crude oil sample for transfer to the analytical column for further separation and quantification.

3.1.7 *programmable temperature vaporizer (PTV), n*—a temperature programmable injector similar to a cool-on-column injector except that the sample is injected cool into a glass liner or insert instead of the WCOT (3.1.6) column and then the temperature is programmed in a manner similar to the on-column injector.

3.1.7.1 *Discussion*—The liner may be replaced, as necessary, to remove non-volatile materials. This injector may be operated in low split mode or direct (no splitting) mode.

3.1.8 *split/splitless injector, n*—a heated capillary inlet or sample introduction system that allows controlled splitting of the injected sample into two unequal portions, the smaller of which goes to the capillary column, and the greater to a vent.

3.1.8.1 *Discussion*—When the vent is closed, the entire sample enters the capillary column and the inlet is operated as a *splitless* injector. When the vent is open, the inlet is operated in the *split* mode and only a portion of the sample reaches the capillary column. The ratio of the split between the capillary column and the vent is calculated as described in 3.1.8.1.

3.1.8.1 *split ratio, n*—in capillary gas chromatography, the ratio of the total flow of carrier gas to the sample inlet versus the flow of the carrier gas to the capillary column, expressed by:

$$\text{split ratio} = (S + C)/C \quad (1)$$

where:

S = flow rate at the splitter vent, and

C = flow rate at the column outlet.

4. Summary of Test Method

4.1 An internal standard, 1-propanol, is added to the sample, which is then introduced into a gas chromatograph equipped with two columns and a flow switching system between the two columns. The sample first passes through the polydimethylsiloxane WCOT column that performs a pre-separation of the methanol and 1-propanol and eliminates unwanted hydrocarbons. The methanol and 1-propanol are transferred to the

analytical PLOT column for oxygenates. While the methanol and 1-propanol are eluting from the analytical PLOT column for oxygenates, auxiliary carrier gas is used to elute higher boiling crude oil hydrocarbons from the pre-column, either in the forward or backflush mode, to yield a stable baseline for the next analysis.

5. Significance and Use

5.1 Methanol is used in production of crude oil to prevent formation of gas hydrates. The presence of residual methanol in crude oils can lead to costly problems in refinery operations.

6. Apparatus

6.1 *Chromatograph*—A multidimensional two-WCOT column gas chromatographic system, capable of adequately resolving methanol and the 1-propanol internal standard and of eliminating hydrocarbon and other interferences, is required for this analysis. Flow switching between the two specified WCOT columns may be accomplished by either using a valve or pneumatic (pressure) switching to redirect flows. The unwanted higher boiling hydrocarbons may be removed from the pre-column either by forward flush or backward flush. The system requires that carrier gas flow controllers must be capable of precise control for the typical pressures required. Such flow controllers are available on gas chromatographs. The precision of this test method was obtained using several instrument configurations described in 6.1.1 – 6.1.5. Other multidimensional configurations may be used, provided that they meet all of the requirements of this test method.

6.1.1 *Configuration A*—Cool-on-column injection (no back-flush of pre-column) with two separate selective heartcuts for the methanol and 1-propanol internal standard. The chromatographic instrument can be operated at the approximate conditions given in Table 1 and Fig. 1. Figs. 2-5 give chromatograms and a calibration curve.

6.1.2 *Configuration B*—Heated split injection with a single heartcut of methanol, 1-propanol and several C₉ minus hydrocarbons transferred to the PLOT column for oxygenates using a six-port valve. The pre-column, located in a separate auxiliary oven, is backflushed to a vent using the six-port valve. Table 2 and Fig. 6 give details of the configuration.

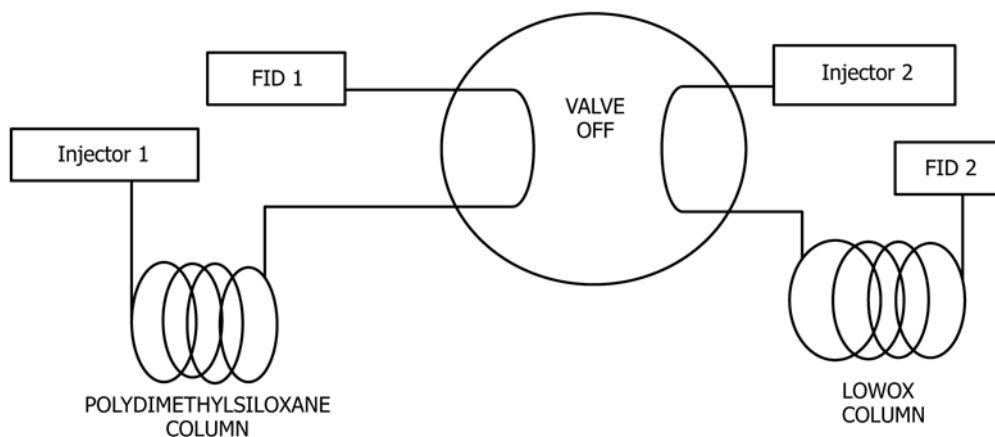
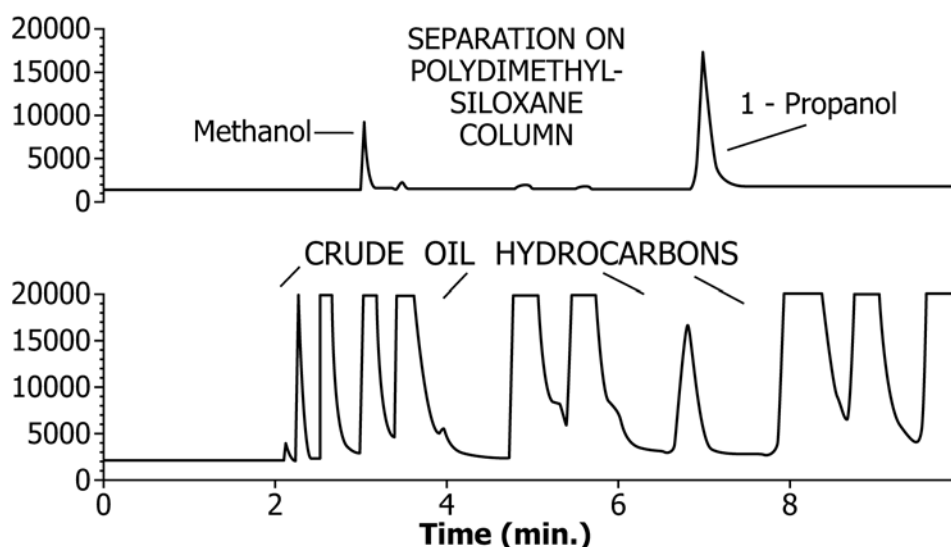

FIG. 1 Valve Diagram for Configuration A



NOTE 1—Two separate injections: TOP/ methanol/1-propanol internal standard solution and BOTTOM/crude oil only.
 FIG. 2 Relative Retention Windows on Polydimethylsiloxane Pre-column in Configuration A Using Monitor FID

6.1.3 *Configuration C*—Heated split injection with a single heartcut for the methanol, 1-propanol and C₉ minus hydrocarbons, followed by backflush of the pre-column through the injection port to remove the high boiling hydrocarbons retained on the pre-column. The chromatographic instrument can be operated at the approximate conditions given in Table 3 and Fig. 7. The pre-column is located in a separate auxiliary oven. Fig. 8 gives a chromatogram obtained with this system.

6.1.4 *Configuration D*—Direct PTV (no splitting) injection with a single heartcut for the methanol and the 1-propanol internal standard and several low boiling hydrocarbons, followed by backflush of the pre-column through the injector to a vent by pressure switching. Table 4 and Figs. 9 and 10 give flow configurations and operating conditions.

6.1.5 *Configuration E*—Split injection using pressure switching between the pre-column and the analytical column. After transfer to the analytical column, pressure is reduced at the inlet and the pre-column is backflushed to remove high boiling crude components. Table 5 and Fig. 11 give the flow configurations and operating conditions.

6.2 *Detector*—At least one, main flame ionization detector (FID) is required. In a two FID detector configuration, the optional second detector is used to monitor the pre-column elution and aids in setting heartcut or transfer times for the methanol and 1-propanol. The main detector's response, proportional to the concentrations of the methanol and 1-propanol, is recorded; the peak areas are measured; and the concentration of methanol is calculated with reference to the 1-propanol internal standard and a calibration curve.

6.3 *Valve or Pneumatic (pressure) Switching*, for systems using valve switching (for example, Configurations A, B in 6.1), a high temperature and low volume valve, located within the gas chromatographic column oven or in a separate oven, capable of performing the functions described in 6.1. The valve connections shall not contribute significantly to chromatographic deterioration. Refer to Fig. 2, Fig. 3, and Fig. 8 for compound peak performance, manufacturer's guidelines and examples given in 6.1 as a guide in assembling the GC system. For example, Valco Model No. A 4C10WP, 1.6 mm (1/16 in.) fittings was used in Configuration A (6.1). Other equivalent